

HS1E SAFETY SWITCHES WITH SOLENOID INTERLOCK

Lightweight and Cost-effective Solenoid Type: Plastic Housing

- Basic unit and solenoid unit in one housing
- Plastic Housing: Light weight
- Ease of Wiring: All the terminal screws are M3.5.
- Available with a red or green indicator
- Selectable from 4 circuit configurations
- When mounting the actuator on a movable door, and the switch on a machine body, the door is mechanically locked when closed.
- Higher Safety: The door is unlocked by a solenoid lock-release signal from a PLC or another source after the machine has stopped.
- In the event of power failure or for machine maintenance, the door can be unlocked using a special tool.
- Flexible Installation: The actuator can be accessed from two directions.
- Available with G1/2 or PG13.5 Conduit Connection
- Also available is a manual unlock key type.

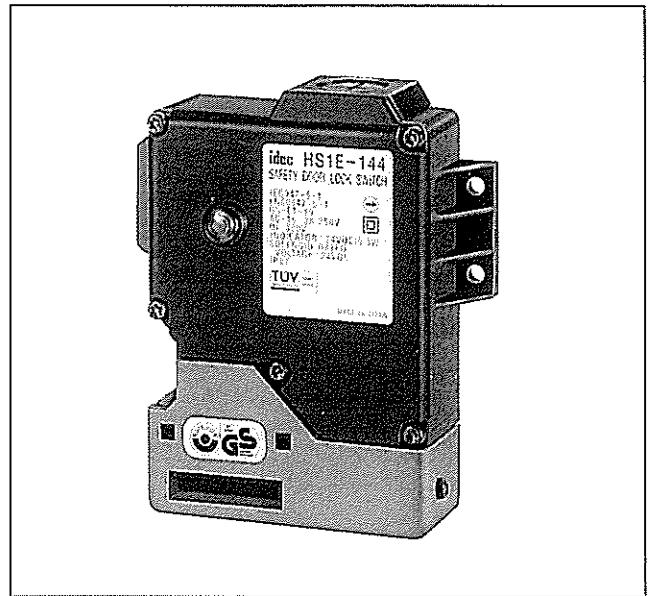

EN1088
EN60947-5-1
IEC60947-5-1



Direct Opening Action



GS-ET-19
BG standard in Germany



Double insulation

Features and Functions

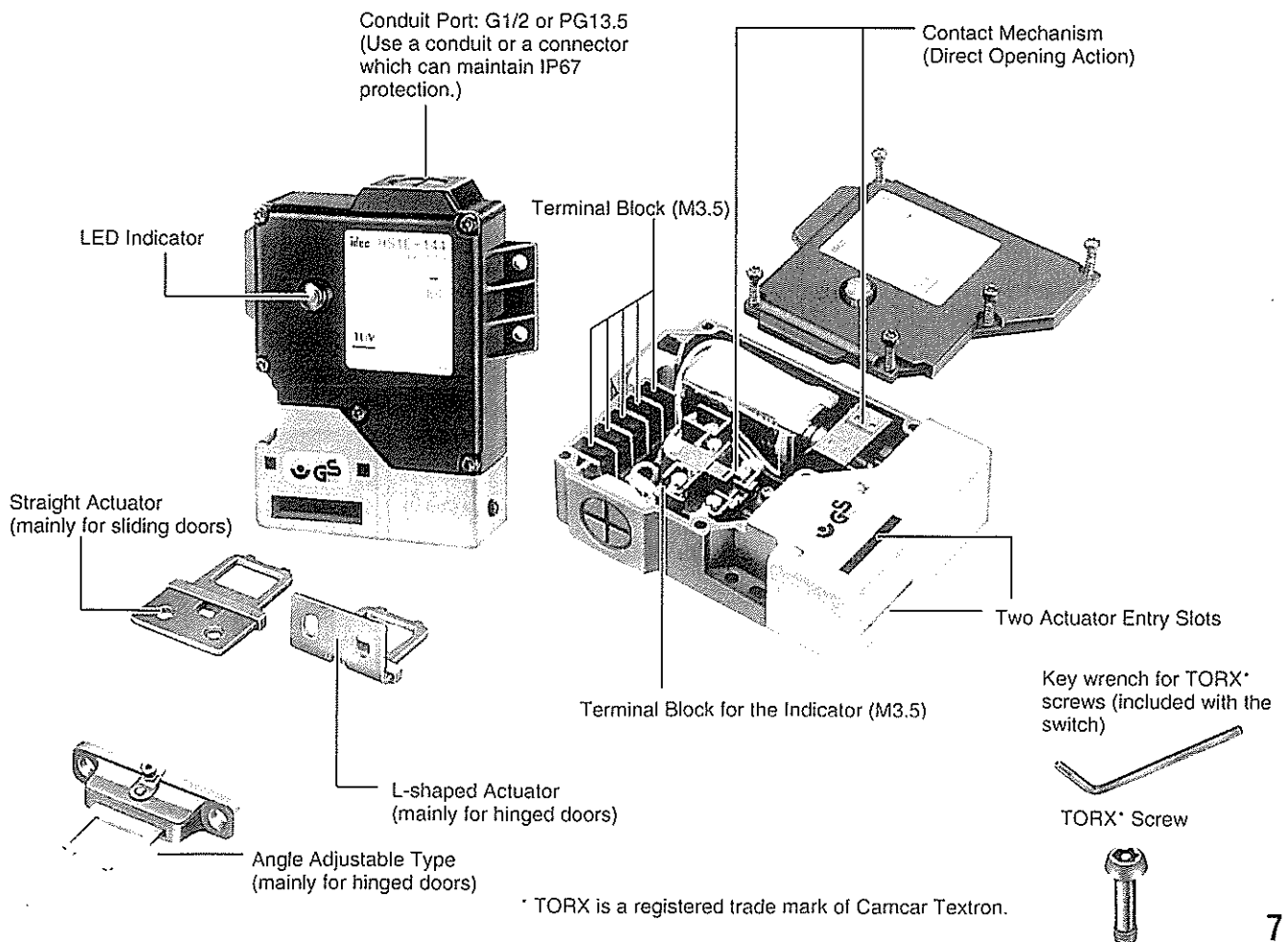

HS1E SAFETY SWITCHES WITH SOLENOID INTERLOCK

TYPES

Type No.	Indicator	Key	Conduit Port
HS1E-□ 40R	Without	Without	G1/2
HS1E-□ 40RP	Without	Without	PG13.5
HS1E-□ 44R-*	With	Without	G1/2
HS1E-□ 44RP-*	With	Without	PG13.5
HS1E-□ 40KR	Without	With	G1/2
HS1E-□ 40KRP	Without	With	PG13.5
HS1E-□ 44KR-*	With	With	G1/2
HS1E-□ 44KRP-*	With	With	PG13.5

Note: • Special key wrench (HS9Z-T1) for removing the cover and manual unlocking is included with the switch (the screwdriver is available separately).
 • Specify the circuit diagram No. in place of □.
 • Red(R) and green(G) indicators are available.
 • Specify the indicator color (R or G) in place of *.
 • Order the actuator separately (not included with the switch).

•ACTUATORS

•KEY WRENCH/SCREWDRIVER FOR TORX* SCREWS

Type No.	Description
HS9Z-A1	Straight Type Actuator (Mainly for sliding doors)
HS9Z-A2	L-shaped Type Actuator (Mainly for hinged doors)
HS9Z-A3	Angle Adjustable Type (Mainly for hinged doors)
HS9Z-T1	Special Key Wrench
HS9Z-T2	Special Screwdriver

* TORX is a registered trade mark of Camcar Textron.

SPECIFICATIONS

Conforming to Standards	EN1088, IEC60947-5-1, EN60947-5-1, GS-ET-19					
Operating Temperature	-20 to +40°C (No freezing)					
Storage Temperature	-40 to +80°C					
Operating Humidity	85% RH maximum (No condensation)					
Altitude	2,000m maximum					
Rated Insulation Voltage (Ui)	300V (between LED or solenoid and ground: 60V)					
Impulse Withstand Voltage (Uimp)	4 kV (between LED or solenoid and ground: 2.5 kV)					
Insulation Resistance	Between live and dead metal parts: 100 MΩ minimum Between live metal part and ground: 100 MΩ minimum Between live metal parts: 100 MΩ minimum Between terminals of the same pole: 100 MΩ minimum					
Electric Shock Protection Class	Class II (IEC60536)					
Pollution Degree	3 (IEC60947-5-1)					
Degree of Protection	IP67 (IEC60529)					
Vibration Resistance	Operating Extremes	10 to 55 Hz, amplitude 0.35 mm				
	Damage Limits	50 m/s² (approx. 5G)				
Shock Resistance	1,000 m/s² (approx. 100G)					
Actuator Tensile Strength when Locked	1,500N minimum					
Operating Speed	1 m/s maximum					
Positive Opening Travel	11 mm minimum					
Positive Opening Force	20N minimum					
Thermal Current (Ith)	Main circuit: 10A, Auxiliary circuit: 3A					
Rated Operating Current (Ie)	Rated operating voltage (Ue)					
			30V	125V	250V	
	Main Circuit	AC	Resistive load (AC12)	10A	10A	6A
			Inductive load (AC15)	10A	5A	3A
	Auxiliary Circuit	DC	Resistive load (DC12)	6A	-	-
			Inductive load (DC13)	3A	0.9A	-
	AC	Resistive load (AC12)	-	3A	3A	
		Inductive load (AC15)	-	-	3A	
	DC	Resistive load (DC12)	3A	-	-	
		Inductive load (DC13)	-	0.9A	-	
Contact Opening Distance	Main circuit: 1.7 mm min., Auxiliary circuit: 1.2 mm min.					
Operating Frequency	900 operations/hour					
Mechanical Life	1,000,000 operations					
Electrical Life	100,000 operations (rated load)					
Conditional Short-circuit Current	100A (IEC60947-5-1)					
Circuit Protection	250V, 10A fuse (Type D01 based on IEC60269-1, 60269-2)					
Solenoid Unit	Rated Operating Voltage	24V DC				
	Rated Current	235 mA				
	Coil Resistance	102Ω (at 20°C)				
	Energizing Voltage	Rated voltage × 85% maximum (at 20°C)				
	De-energizing Voltage	Rated voltage × 10% minimum (at 20°C)				
	Continuous Applicable Voltage	Rated voltage × 110%				
	Continuous Applicable Duration	Not specifically limited				
	Insulation Class	Class B				
Indicator	Rated Operating Voltage	24V DC				
	Rated Current	10 mA				
	Light Source	LED lamp				
	Lens Color	Red or Green (12 mm dia. Lens)				
Weight	Approx. 500g					

ORDERING INFORMATION

HS1E - 2 4 4 K R P - R

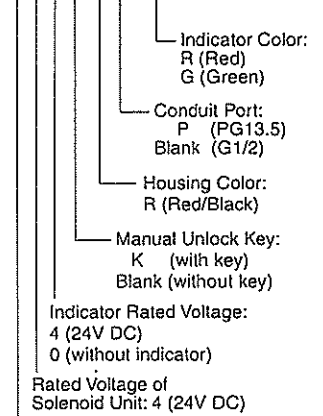

Circuit Diagram No.

	Main Circuit	Auxiliary Circuit
Blank:	1NC-1NC	1NO-1NO
1:	1NC-1NC	1NO
2:	1NC-1NC	1NC-1NC
3:	1NC-1NC	1NC

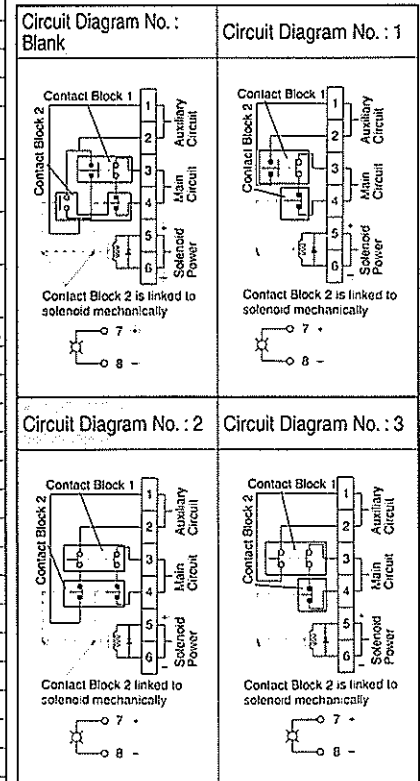

Note: Refer to pages 9 and 10 for HS1E circuit configurations.

HSE SAFETY SWITCHES WITH SOLENOID INTERLOCK

Circuit Diagrams and Application Examples

• Circuit Diagram No.: Blank (Main Circuit: 1NC-1NC, Auxiliary Circuit: 1NO-1NO)

Switch/ Door Status	Status 1	Status 2	Status 3	Status 4	When unlocked manually
	•Door closed •Machine ready to operate •Solenoid de-energized	•Door closed •Machine cannot be started •Solenoid energized	•Door opened •Machine cannot be started •Solenoid energized	•Door opened •Machine cannot be started •Solenoid de-energized	•Door closed •Machine cannot be started •Solenoid de-energized
Door					
Circuit Diagram	 Contact Block 2 is linked to solenoid mechanically	 Contact Block 2 is linked to solenoid mechanically	 Contact Block 2 is linked to solenoid mechanically	 Contact Block 2 is linked to solenoid mechanically	 Contact Block 2 is linked to solenoid mechanically
Main Circuit	3-4: Closed	3-4: Open	3-4: Open	3-4: Open	3-4: Open
Auxiliary Circuit	1-2: Open	1-2: Closed	1-2: Closed	1-2: Closed	1-2: Closed
Solenoid	5-6: Power OFF	5-6: Power ON	5-6: Power ON	5-6: Power OFF	5-6: Power OFF

• Circuit Diagram No.: 1 (Main Circuit: 1NC-1NC, Auxiliary Circuit: 1NO)

Switch/ Door Status	Status 1	Status 2	Status 3	Status 4	When unlocked manually
	•Door closed •Machine ready to operate •Solenoid de-energized	•Door closed •Machine cannot be started •Solenoid energized	•Door opened •Machine cannot be started •Solenoid energized	•Door opened •Machine cannot be started •Solenoid de-energized	•Door closed •Machine cannot be started •Solenoid de-energized
Door					
Circuit Diagram	 Contact Block 2 is linked to solenoid mechanically	 Contact Block 2 is linked to solenoid mechanically	 Contact Block 2 is linked to solenoid mechanically	 Contact Block 2 is linked to solenoid mechanically	 Contact Block 2 is linked to solenoid mechanically
Main Circuit	3-4: Closed	3-4: Open	3-4: Open	3-4: Open	3-4: Open
Auxiliary Circuit	1-2: Open	1-2: Open	1-2: Closed	1-2: Closed	1-2: Open
Solenoid	5-6: Power OFF	5-6: Power ON	5-6: Power ON	5-6: Power OFF	5-6: Power OFF

Main Circuit: used to enable the machine to start only when the main circuit is closed.

Auxiliary Circuit: used to indicate whether the main circuit or door is open or closed.

Terminals 7 and 8 are used for the LED indicator, and are isolated from solenoid or door status.

Wire the terminals only when needed.

HS1E SAFETY SWITCHES WITH SOLENOID INTERLOCK

Circuit Diagrams and Application Examples

• Circuit Diagram No.: 2 (Main Circuit: 1NC-1NC, Auxiliary Circuit: 1NC-1NC)

Switch/ Door Status	Status 1	Status 2	Status 3	Status 4	When unlocked manually
	<ul style="list-style-type: none"> •Door closed •Machine ready to operate •Solenoid de-energized 	<ul style="list-style-type: none"> •Door closed •Machine cannot be started •Solenoid energized 	<ul style="list-style-type: none"> •Door opened •Machine cannot be started •Solenoid energized 	<ul style="list-style-type: none"> •Door opened •Machine cannot be started •Solenoid de-energized 	<ul style="list-style-type: none"> •Door closed •Machine cannot be started •Solenoid de-energized
Door					
Circuit Diagram	<p>Contact Block 2 linked to solenoid mechanically</p>	<p>Contact Block 2 is linked to solenoid mechanically</p>	<p>Contact Block 2 is linked to solenoid mechanically</p>	<p>Contact Block 2 is linked to solenoid mechanically</p>	<p>Contact Block 2 is linked to solenoid mechanically</p>
Main Circuit	3-4: Closed	3-4: Open	3-4: Open	3-4: Open	3-4: Open
Auxiliary Circuit	1-2: Closed	1-2: Open	1-2: Open	1-2: Open	1-2: Open
Solenoid	5-6: Power OFF	5-6: Power ON	5-6: Power ON	5-6: Power OFF	5-6: Power OFF

• Circuit Diagram No.: 3 (Main Circuit: 1NC-1NC, Auxiliary Circuit: 1NC)

Switch/ Door Status	Status 1	Status 2	Status 3	Status 4	When unlocked manually
	<ul style="list-style-type: none"> •Door closed •Machine ready to operate •Solenoid de-energized 	<ul style="list-style-type: none"> •Door closed •Machine cannot be started •Solenoid energized 	<ul style="list-style-type: none"> •Door opened •Machine cannot be started •Solenoid energized 	<ul style="list-style-type: none"> •Door opened •Machine cannot be started •Solenoid de-energized 	<ul style="list-style-type: none"> •Door closed •Machine cannot be started •Solenoid de-energized
Door					
Circuit Diagram	<p>Contact Block 2 is linked to solenoid mechanically</p>	<p>Contact Block 2 is linked to solenoid mechanically</p>	<p>Contact Block 2 is linked to solenoid mechanically</p>	<p>Contact Block 2 is linked to solenoid mechanically</p>	<p>Contact Block 2 is linked to solenoid mechanically</p>
Main Circuit	3-4: Closed	3-4: Open	3-4: Open	3-4: Open	3-4: Open
Auxiliary Circuit	1-2: Closed	1-2: Closed	1-2: Open	1-2: Open	1-2: Closed
Solenoid	5-6: Power OFF	5-6: Power ON	5-6: Power ON	5-6: Power OFF	5-6: Power OFF

Main Circuit: used to enable the machine to start only when the main circuit is closed.

Auxiliary Circuit: used to indicate whether the main circuit or door is open or closed.

Terminals 7 and 8 are used for the LED indicator, and are isolated from solenoid or door status.

Wire the terminals only when needed.

HS1E SAFETY SWITCHES WITH SOLENOID INTERLOCK

DIMENSIONS

- HS1E with indicator – using the straight actuator (HS9Z-A1)

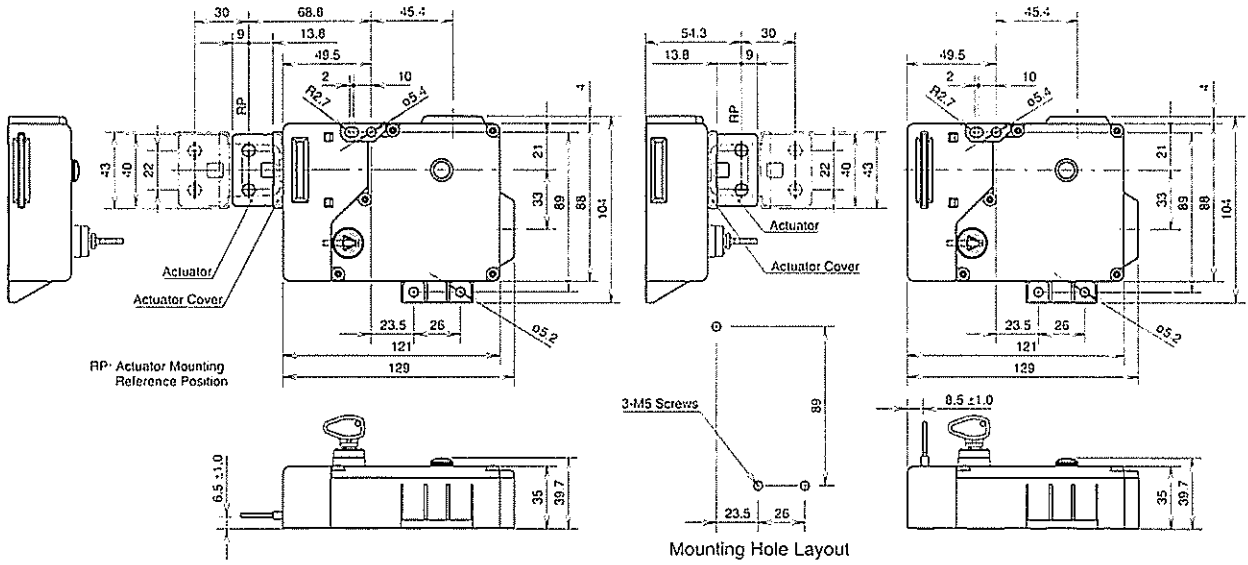

- HS1E with indicator – using the L-shaped actuator (HS9Z-A2)

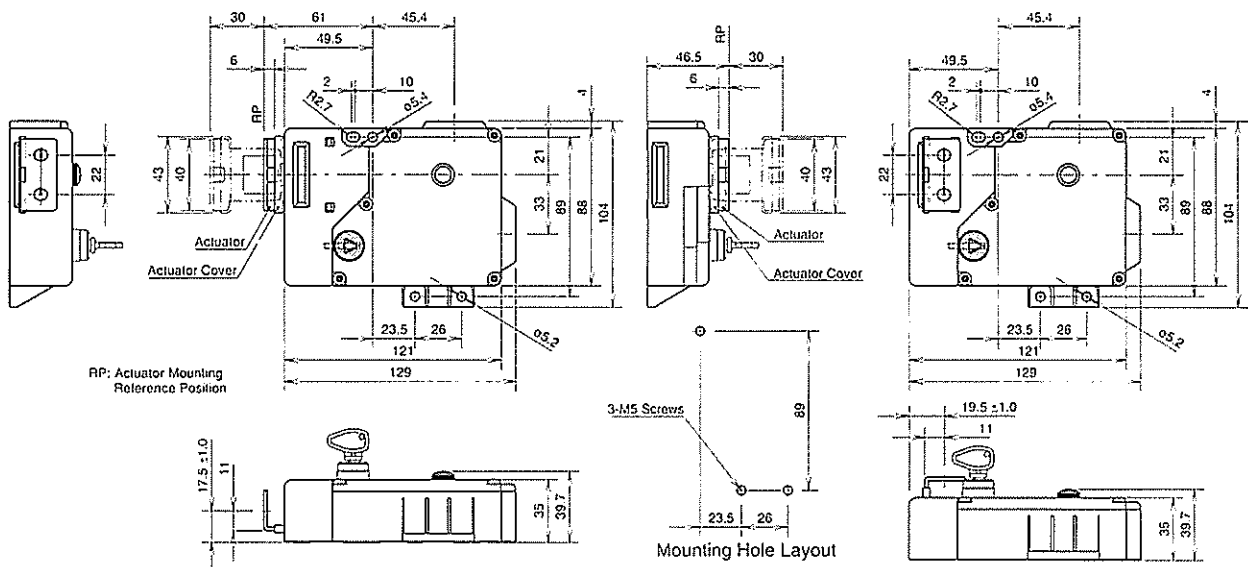

ACTUATORS

- Straight Type (mainly for sliding doors)

HS9Z-A1

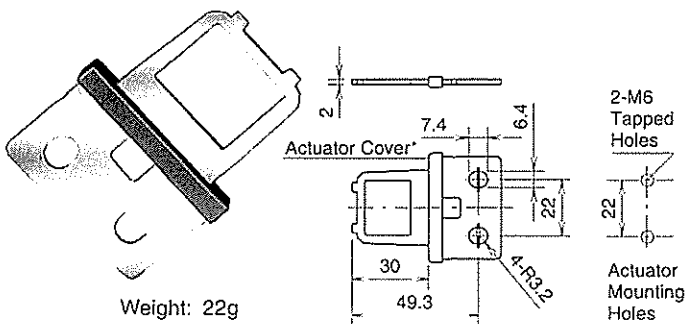

* After installing the actuator, remove the actuator cover.

- L-shaped Type (mainly for hinged doors)

HS9Z-A2

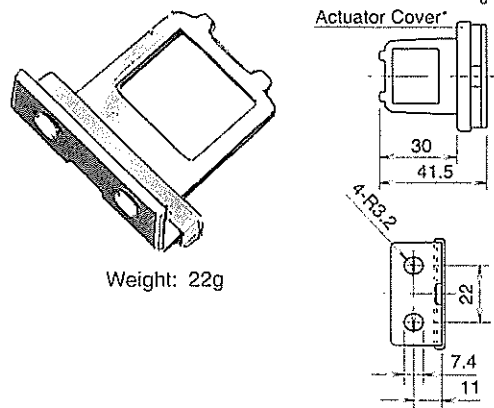

- Angle Adjustable Actuator (mainly for hinged doors)

See page 19 for photos and dimensions.

All dimensions in mm.